

Producing digital assets at scale with Machine Intelligence

The problems

- We were spending weeks getting one digital asset approved.
- Subjective changes.
- Team availability.
- Production costs.
- Low value perception.
- No A/B testing.
- Didn't love the Yt or Fb tools.

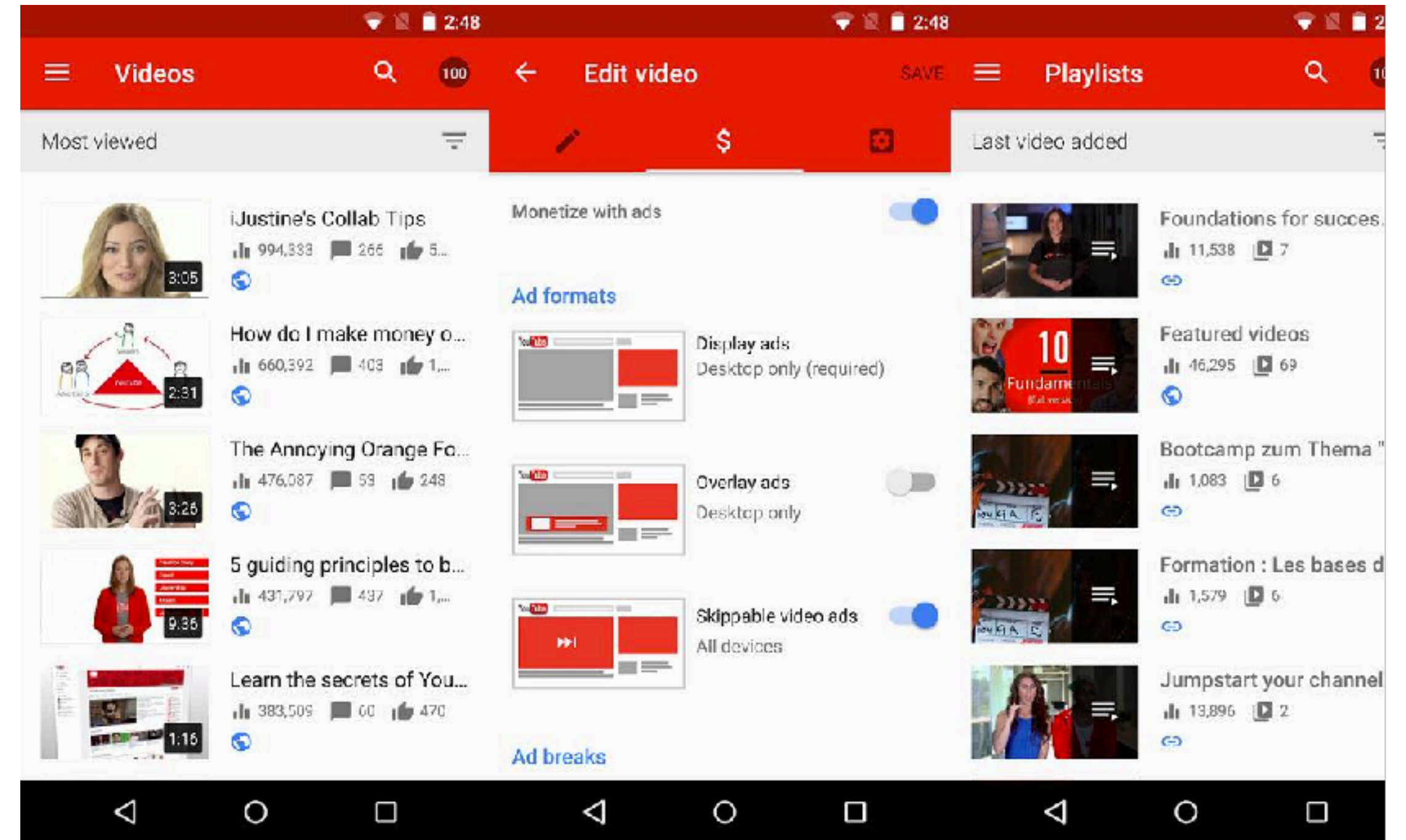

The reason(s)

- Waterfall model.
- Heavy traffic structures.
- Wrong briefs.

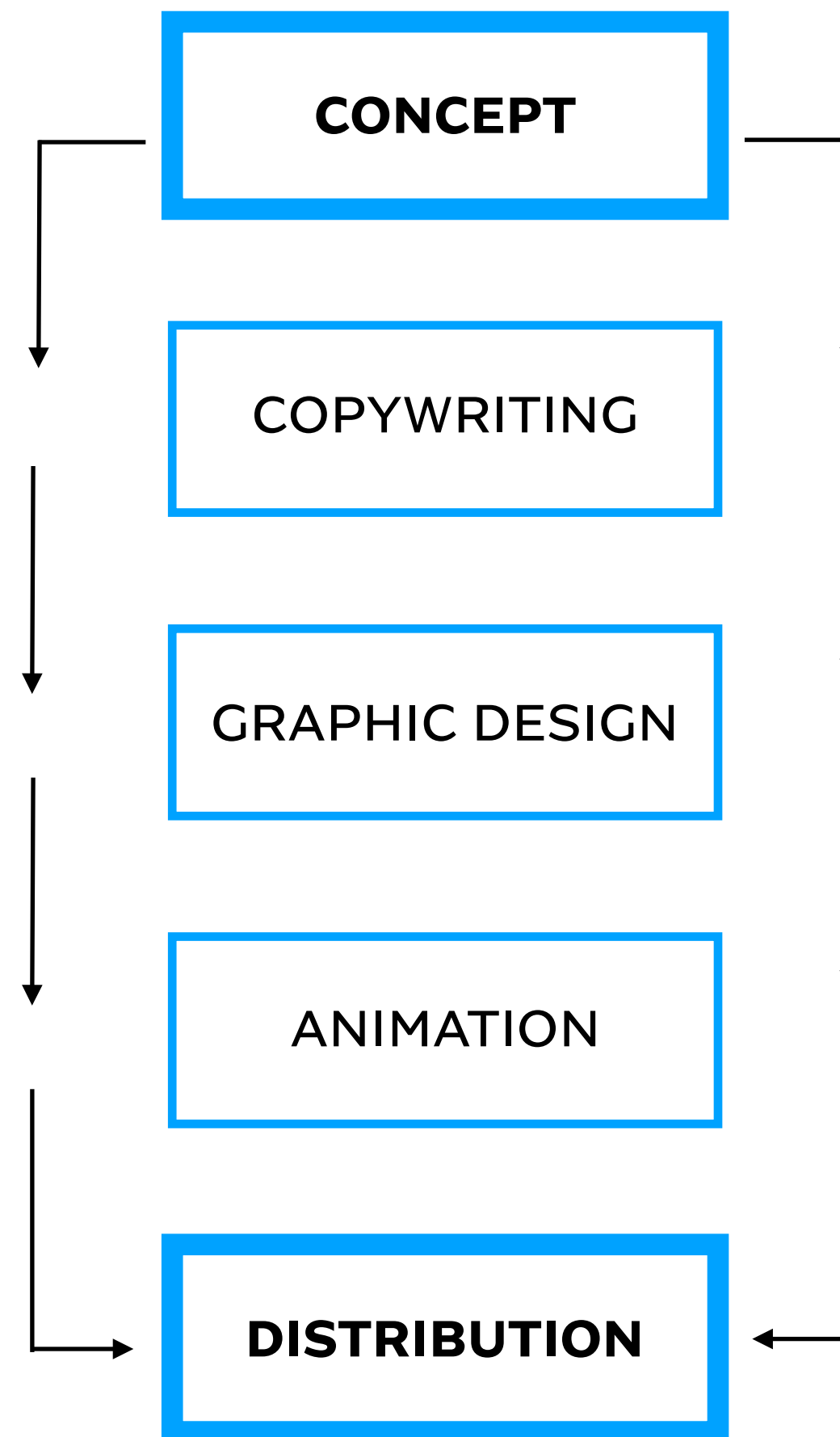

WATERFALL MODEL

The Waterfall Model follows a **sequential order**, and so project development team only moves to next phase of development if the previous step completed successfully.

Changing the approach

AGILE METHODOLOGY

Agile methodology is a practice that helps continuous iteration of development, so that **activities are concurrent.**

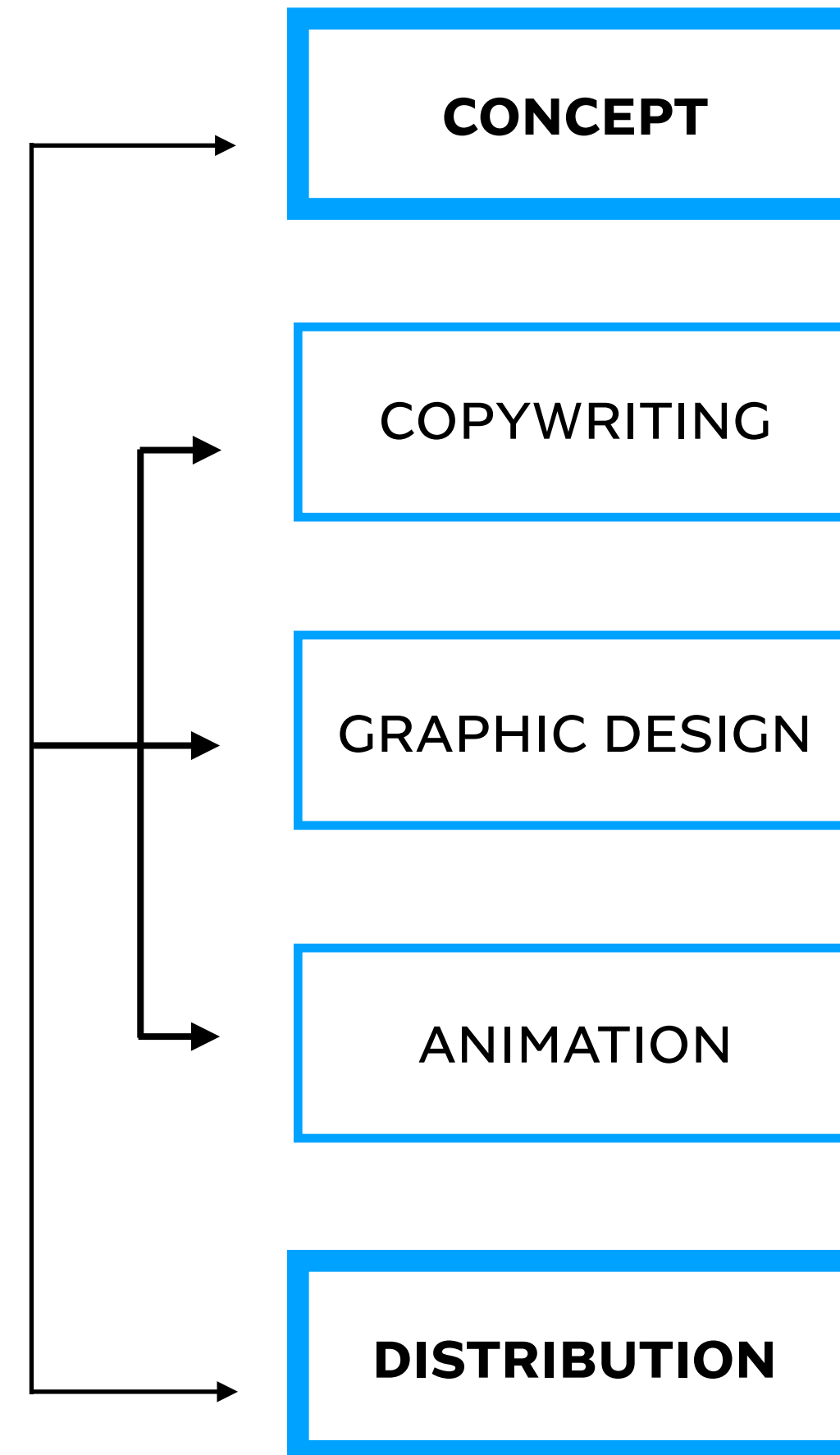

The task force

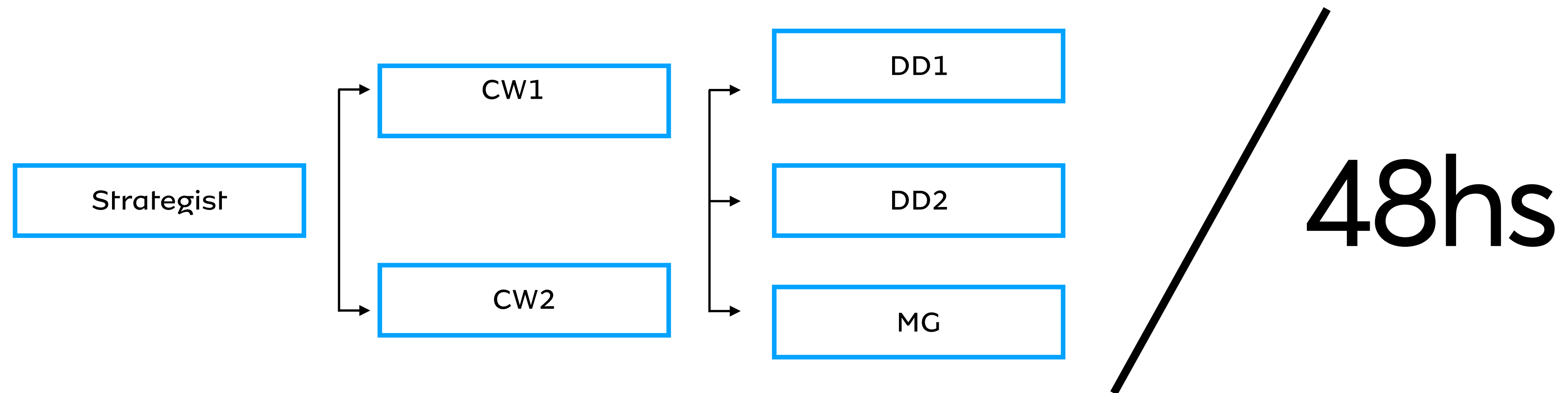

The meeting 🤔

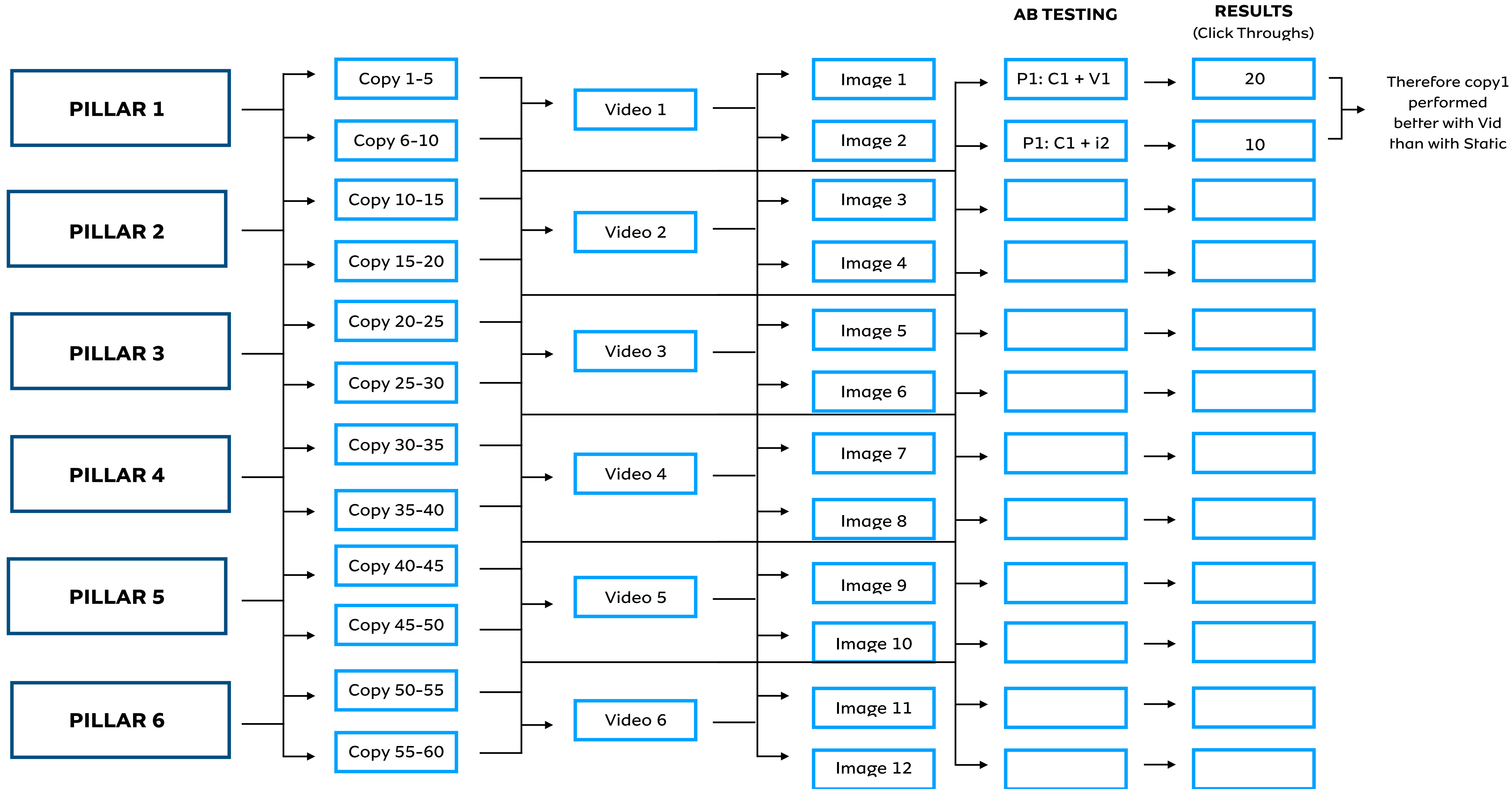

Regrouping

PILLARS

1GB FREE

CAKE CRUSH

ZERO RATED

SAFETY

RECHARGE

BALANCE

COPY VARIATIONS *3 P/C

1GB free on download

Text:

- Get that winning feeling with 1GB of data for free when you download the new MTN app!
- Download the new MTN app and get 1GB of data, absolutely free.
- Get 1GB of data for free when you download the new MTN app.
- Download the new MTN app and get that 'top dog' feeling with 1GB free data!
- Get that BOSS feeling when you download the new MTN app and get 1GB free data.

Headline:

- 1GB free on download
- Download and get 1GB free
- Free 1GB on download
- 1GB free data on download
- Get 1GB free on download

Link description:

- Download and get 1GB free data!
- Get 1GB free data on download
- Free 1GB data on download
- Download and get 1GB free data
- Receive 1GB free on download

Cake Crush

Text:

- WIN your share of over R100 Million in rewards on the new MTN app when you play MTN Cake Crush and get that 'top-hi-wad' feeling.
- Get that winning feeling with your share of over R100 Million in rewards when you play MTN Cake Crush on the new MTN app!
- Get that 'Chief' feeling with your share of over R100 Million in rewards on the new MTN app when you play MTN Cake Crush!
- Play MTN Cake Crush on the new MTN app to get that 'damn, son!' feeling with your share of over R100 Million in rewards!
- Play MTN Cake Crush to get that 'CEO' feeling with your share of over R100 Million in rewards. Download the new MTN app.

Headline:

- Play MTN Cake Crush
- Win with MTN Cake Crush
- R100 Million in rewards
- WIN your share!
- Crush Cake and WIN!

Link description:

- Play MTN Cake Crush and WIN!
- Win your share of R100 Million
- Win big with MTN Cake Crush
- Play MTN Cake Crush
- WIN with MTN Cake Crush!

Recharge

Text:

- Recharging is so quick and easy on the new MTN app, you'll get that winning feeling.
- Get that winning feeling when you recharge quickly and conveniently, from the security of your device with the new MTN app.
- Recharge any time of the day or night, from your device. Download the new MTN app to understand convenience.
- Recharge wherever you are with the new MTN app. Download it now to get that winning feeling with the safest way to top up.
- Get that 'he is convenient' feeling when you see the how quick and easy recharging is, wherever you are, through the new MTN app.

Headline:

- Recharge with ease
- Top up on the go
- Recharge easily
- Recharging is a breeze
- Top up quickly & easily

Link description:

- Recharging is super easy
- Top up safely and securely
- Recharge quickly and easily
- Recharge quick quick
- Recharge and save

DESIGN TEMPLATES

Recharge



Cake Crush

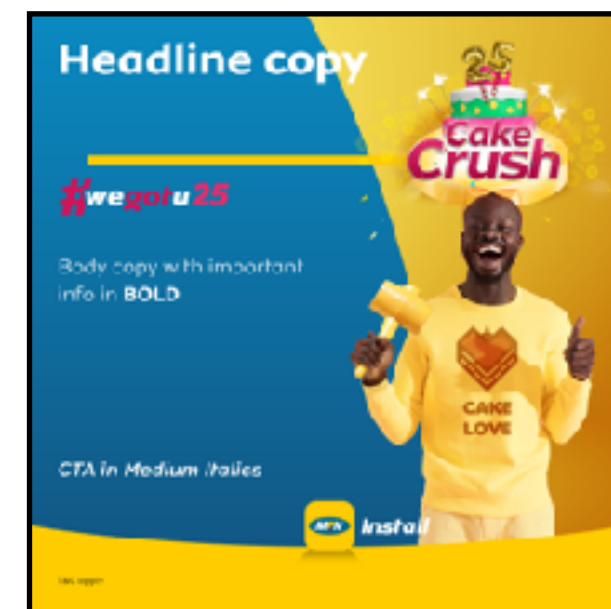

Safety

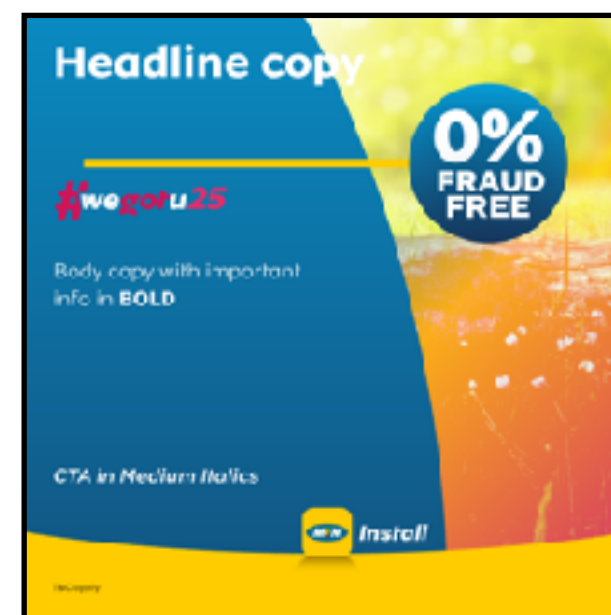

ANIMATIONS X6

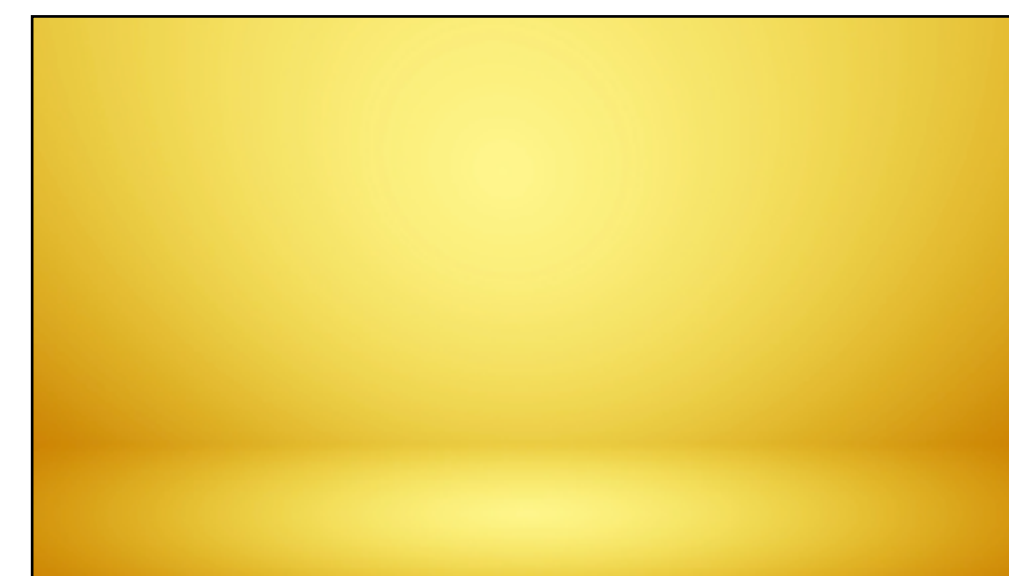
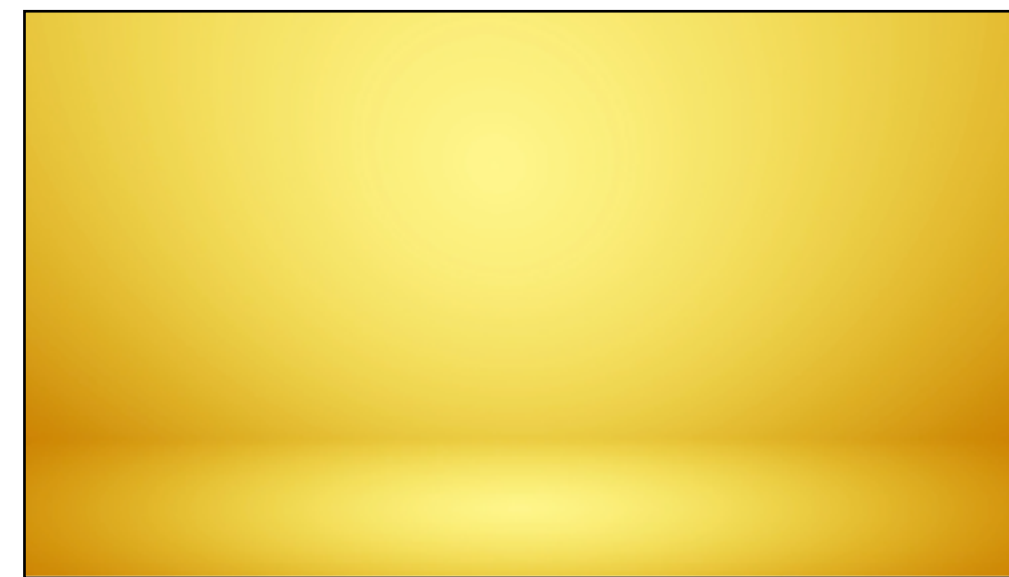

OUTPUTS

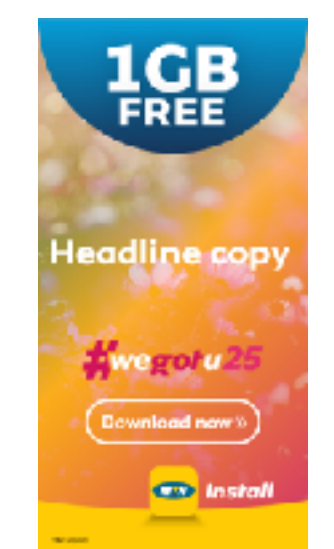
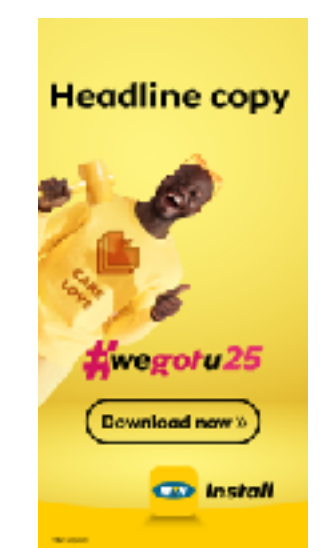

Results

- Turn around time = 48hs.
- 1000+ executions.
- DCO from theory to practice.
- Leaner process and scalability.
- Value perception +
- Change by output instead of hours?

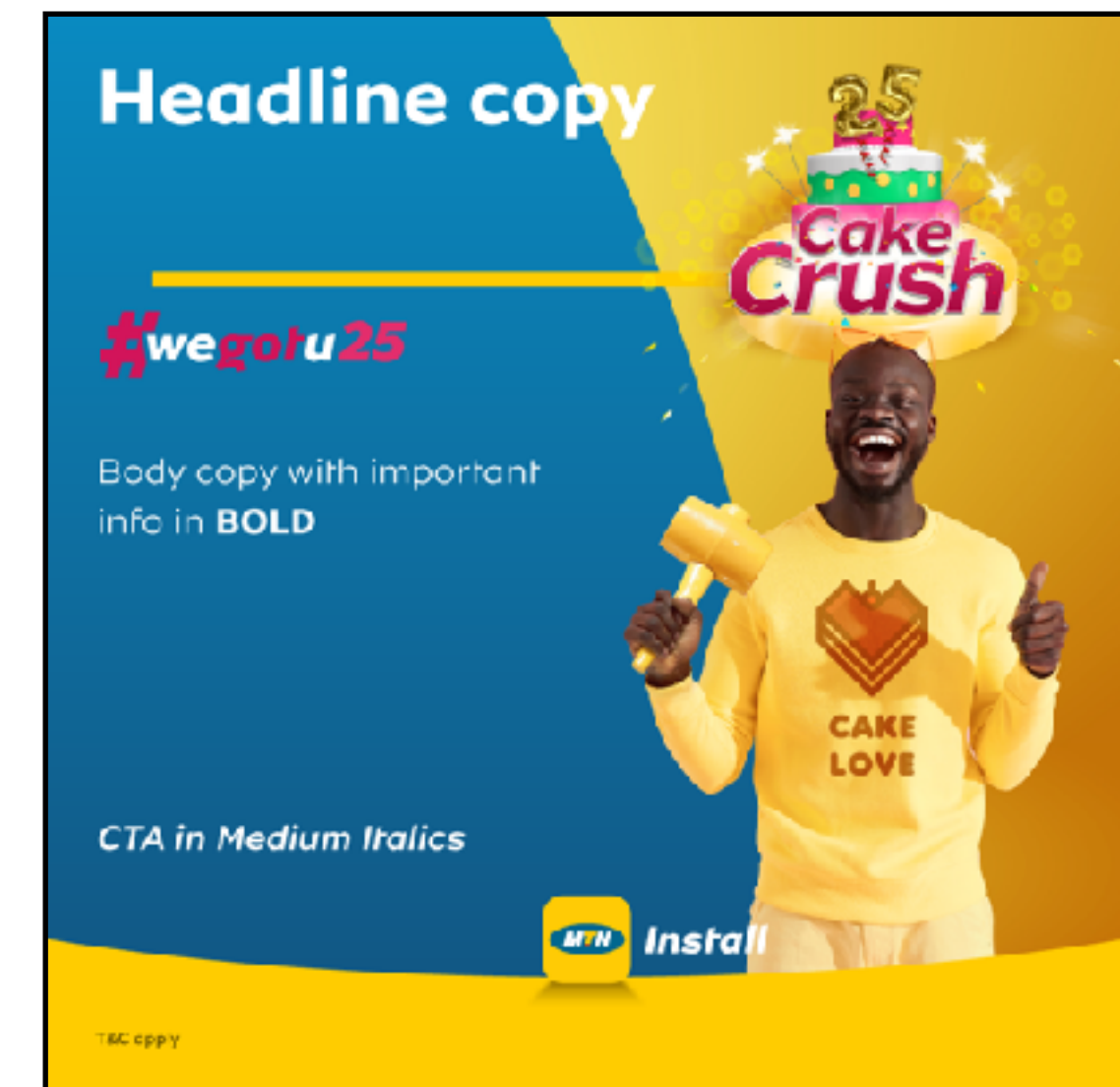
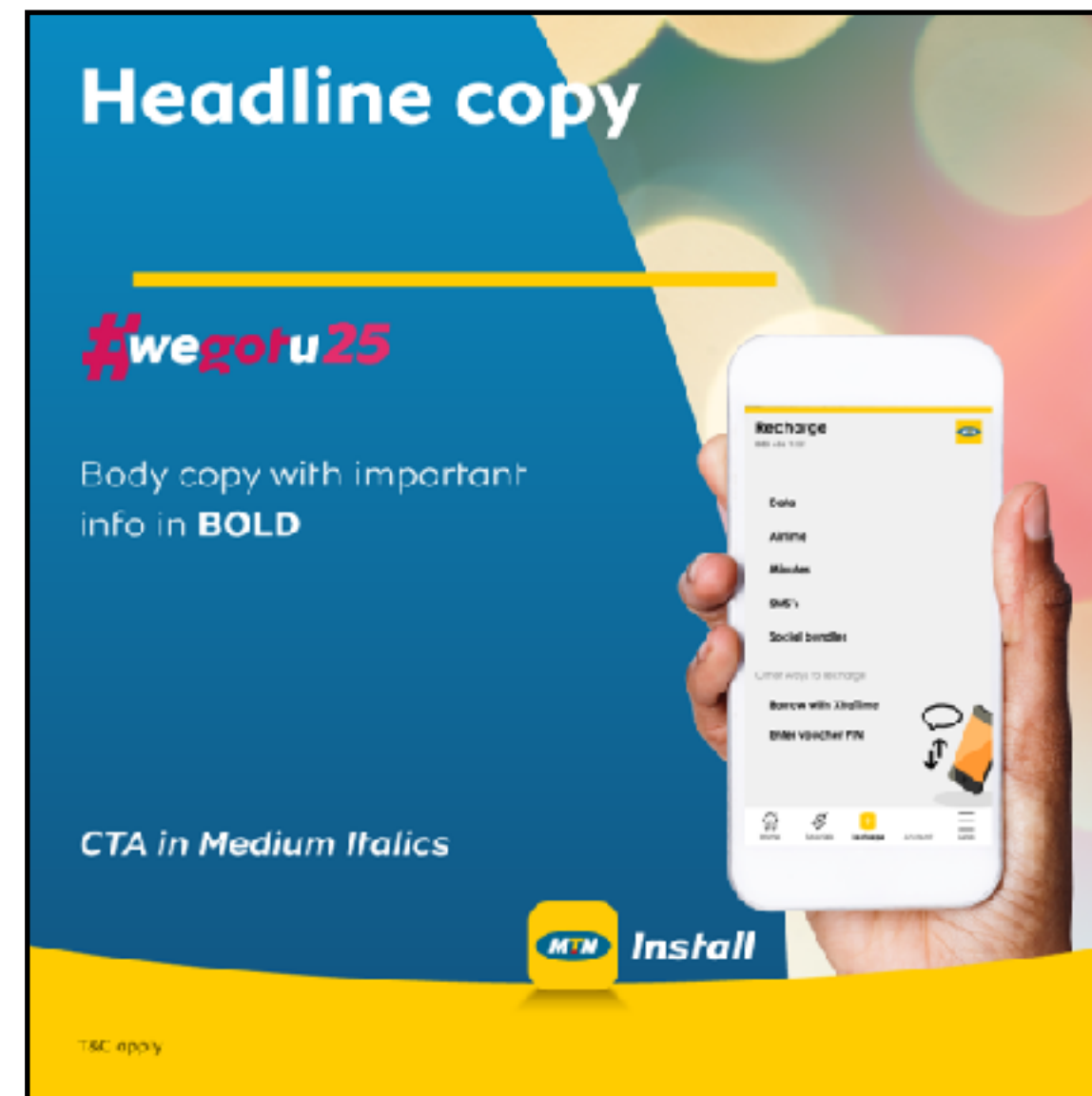
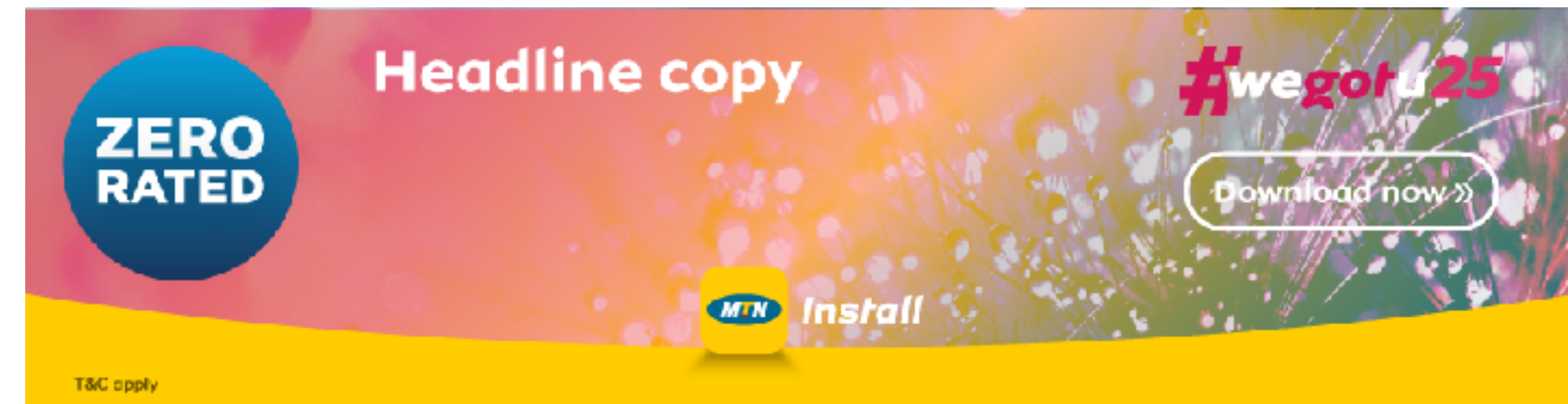

Then we wondered, could we build an RPA tool
to automate this? 🤖





So we did...

STEP 1 Select templates



Facebook

 <p>Timeline post standard 850 x 720 Jpg image</p>	 <p>Profile photo 1024 x 1024 Jpg image</p>	 <p>Cover photo 850 x 314 Jpg image</p>	 <p>Cover photo at 2x 1700 x 630 Jpg image</p>
---	--	---	--

Instagram

 <p>Timeline portrait 850 x 540 Jpg image</p>	 <p>HD Square sized 1080 x 1080 Jpg image</p>	 <p>Timeline post standard 760 x 760 Jpg image</p>	 <p>Vertical story post 1200 x 600 Jpg image</p>
---	---	---	---

Linkedin

 <p>Timeline post standard 1024 x 850 Jpg image</p>	 <p>Profile cover banner 960 x 541 Jpg image</p>	 <p>Promoted Post 720 x 540 Jpg image</p>
--	---	---

STEP 2 Upload backgrounds



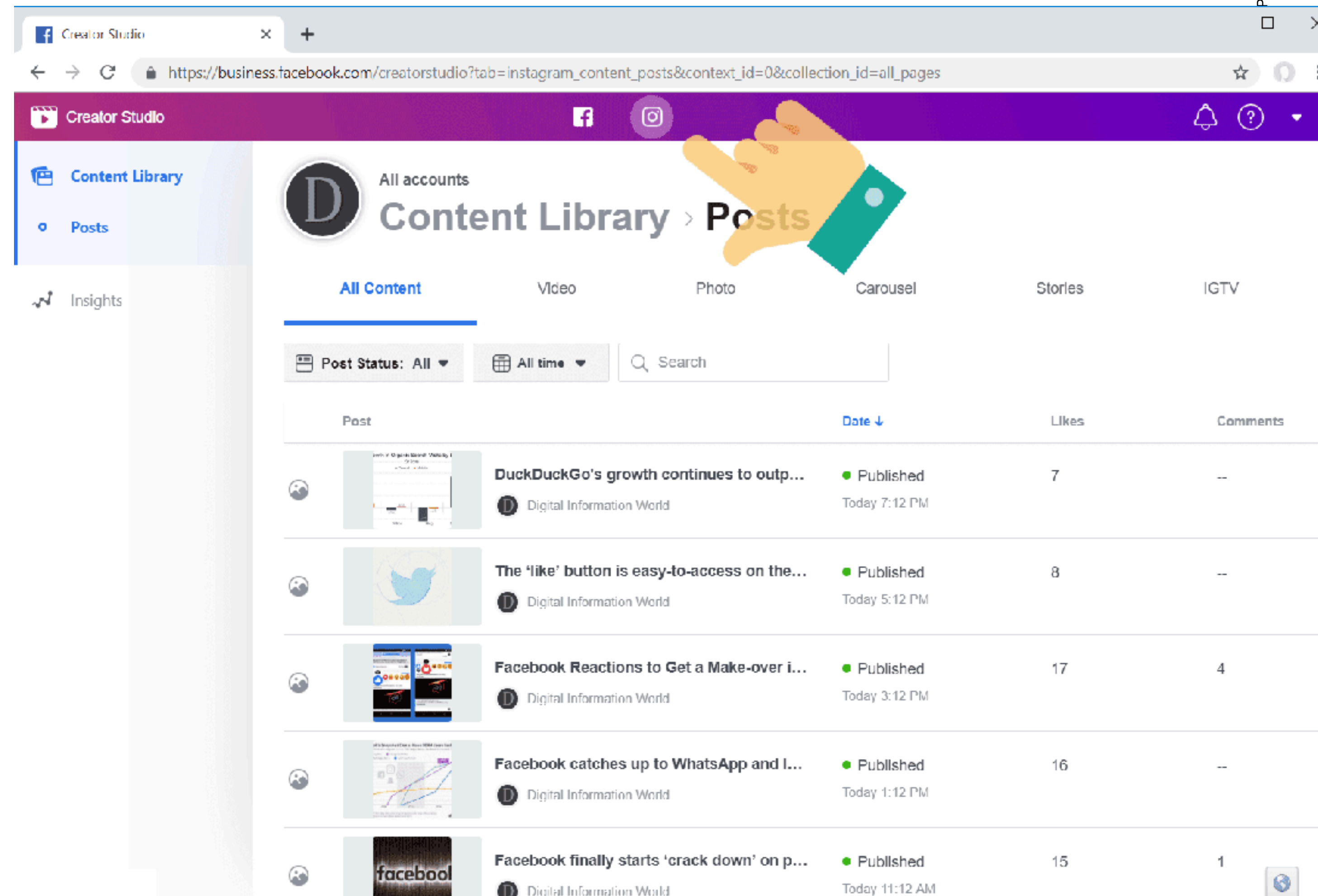

STEP 3 Customize

Cons

- How do we charge for this?
- Limited creativity.
- Repetitive assets.
- Media tracking.
- Limited to digital (for now).

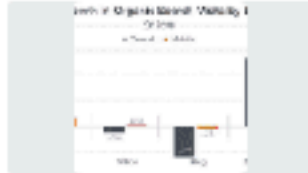

The screenshot shows the Facebook Creator Studio interface. The browser address bar displays the URL: https://business.facebook.com/creatorstudio?tab=instagram_content_posts&context_id=0&collection_id=all_pages. The page title is "Content Library > Posts". The left sidebar contains navigation options: "Content Library", "Posts", and "Insights". The main content area shows a list of posts from the account "Digital Information World". A hand icon is pointing to the Instagram icon in the top navigation bar.

Post	Date	Likes	Comments
 DuckDuckGo's growth continues to outp... Digital Information World	Published Today 7:12 PM	7	--
 The 'like' button is easy-to-access on the... Digital Information World	Published Today 5:12 PM	8	--
 Facebook Reactions to Get a Make-over i... Digital Information World	Published Today 3:12 PM	17	4
 Facebook catches up to WhatsApp and I... Digital Information World	Published Today 1:12 PM	16	--
 Facebook finally starts 'crack down' on p... Digital Information World	Published Today 11:12 AM	15	1

Thank you!
david.uribe@tbwa.com